

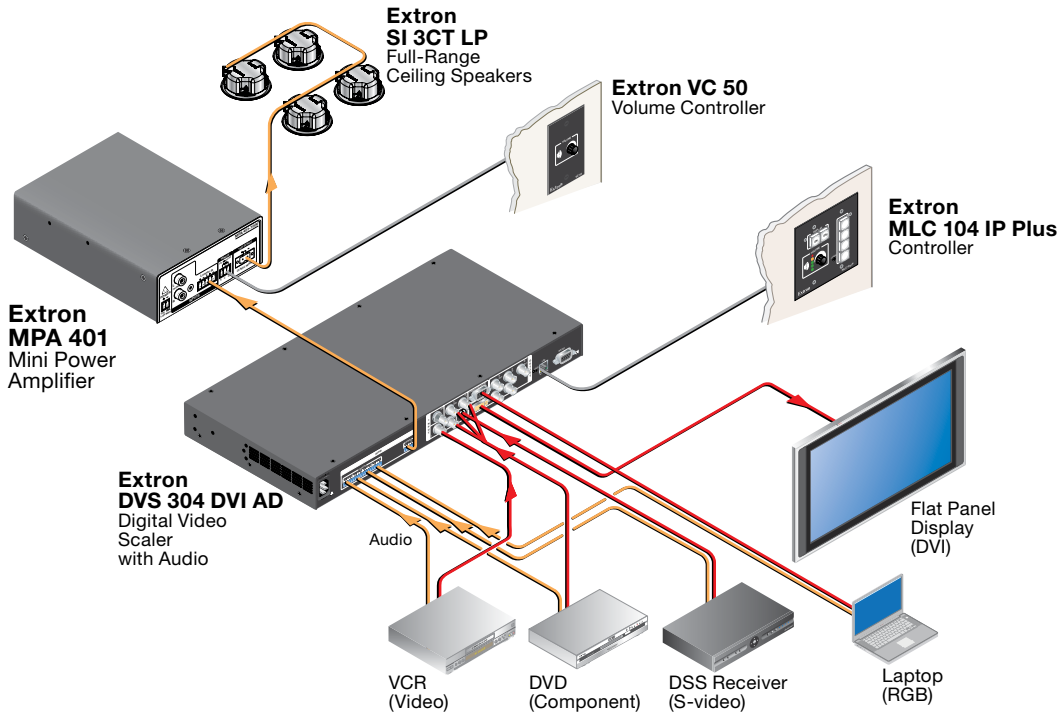

MPA 401-70V and MPA 401-100V • Setup Guide

This guide provides basic instructions for an experienced installer to install and configure the Extron MPA 401-70V and MPA 401-100V mini power amplifiers.

IMPORTANT:
Refer to www.extron.com for the complete user guide and installation instructions before connecting the product to the power source.



Step 1 — Turn all of the equipment off and disconnect all power sources.

Step 2 — Mount the amplifier in either a plenum space, on a rack, under a desk, or on a projector.

ATTENTION: Although the amplifier is plenum rated, the power supply provided with it is not. The power supply must not be placed in the plenum space. Cables to and from the amplifier must be plenum rated.

NOTE: Use only the two round mounting holes for mounting the MPA 401. The other four (hexagonal) holes anchor stand-offs for the internal circuit boards. Using them may damage the amplifier and does not provide secure mounting for the unit.

Step 3 — Attach the speakers to the MPA 401 using the 2-pole, 5 mm screw-lock captive screw speaker receptacle on the rear panel. (The old and new silk screens for the MPA 401-100V are shown to the right).

ATTENTION: Do not ground or short the speaker outputs as this will damage the amplifier.

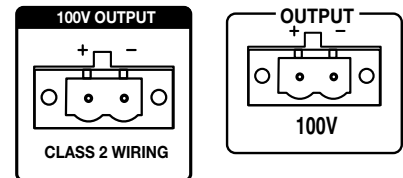

NOTE: The mono audio speaker receptacle may be labeled in one of two ways (see the images to the right). The wiring and function are the same whichever way the product is labeled.

Step 4 — Attach sources to the MPA 401 unit from the audio source or projector. The three rear panel audio inputs can be used individually or together:

- One pair of RCA receptacles (unbalanced)
- One 3.5 mm stereo tip-ring-sleeve receptacle (unbalanced)
- One 3.5 mm, 5-pole captive screw receptacle (balanced or unbalanced)

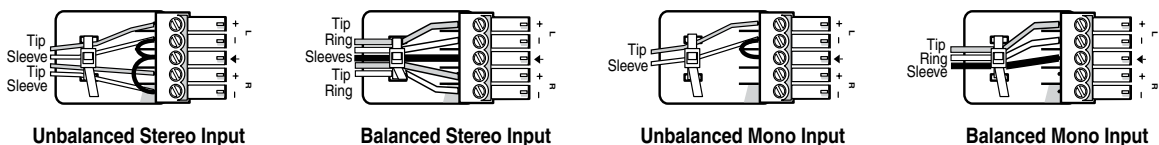
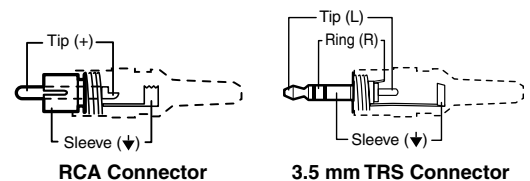

MPA 401-70V and MPA 401-100V • Setup Guide (Cont'd)

NOTES:

- The input receptacle may be labeled in one of two ways: the ground pins of the input connector port may be labeled ∇ or \neq (see the images to the right). The wiring and function are the same whichever way the product is labeled
- The MPA 401 amplifier sums the left and right signals from both the TRS and RCA inputs to form Sum 1. Sum 1 is then weighted. At the same time, the amplifier sums the left and right signals from the captive screw input to form Sum 2. Sum 1 and Sum 2 are then summed together to form a single mono signal. See figure 6 on page 9 of the *MPA 401 Series User Guide* for more details.
- The captive screw, RCA and TRS inputs are buffered.

Ensure that the audio output of the projector is set to variable out. Multiple input options can be used simultaneously and result in summing.

Step 5 — Connect power cords to the MPA 401 and other audio equipment. The MPA 401 ships with an Extron 36 W desktop power supply.

Connect the pre-wired captive screw connector into one of the two pole, 3.5 mm captive screw outlets on the power supply and the other end into the power receptacle on the amplifier (see the figure to the right). The power cord connectors are correctly wired when shipped.

ATTENTION:

- See the attention notices in the Power Input section of the *MPA 401 Series User Guide* for important information about using power supplies.
- When the 36 W power supply is connected to the MPA 401, it must not be shared with any other devices.

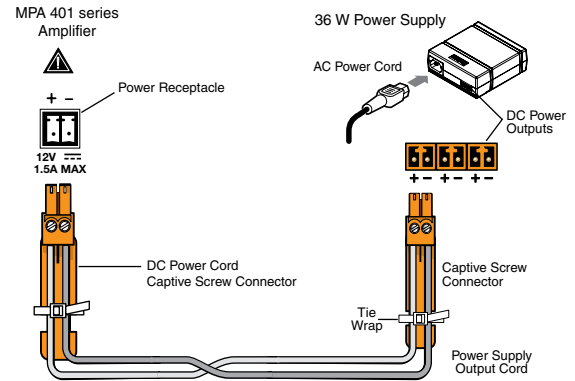

Step 6 — Adjust the MPA 401 input level, bass, and treble from the front panel (see figure at right).

1. If necessary, unplug the remote connector from the unit (see step 7, below).
2. If connecting the amplifier to a system with adjustable volume, set the volume to its lowest point. Then adjust the MPA 401 front panel level potentiometer fully counterclockwise.
3. Set the system volume to its maximum volume level (no sound should come out).
4. Return to the MPA 401 and raise the level until sound distortion first occurs, then lower slightly until the distortion disappears. This setting ensures that, whatever the system volume setting may be, no clipping occurs.
5. Adjust bass and treble to preference.

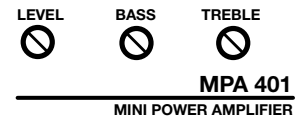

Step 7 — The rear panel 3-pole Remote captive screw receptacle on the amplifier can be used for remote control of the volume by an Extron volume controller such as an Extron VCM 100 AAP, VC 50, or MLA VC10 Plus. A MediaLink controller can also adjust the audio volume via a network connection or by IR remote (see the *MPA 401 Series User Guide*).

NOTE: Control signal ground pins may be labeled as \neq or "G." The wiring and function are the same, whichever way the product is labeled.

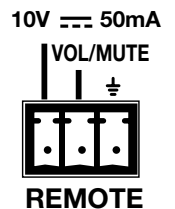
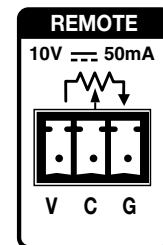

Extron Headquarters +1.800.633.9876 (Inside USA/Canada Only)	Extron USA - West +1.714.491.1500 +1.714.491.1517 FAX	Extron USA - East +1.919.850.1000 +1.919.850.1001 FAX	Extron Europe +800.3987.6673 (Inside Europe Only) +31.33.453.4040 +31.33.453.4050 FAX	Extron Asia +65.6383.4400 +65.6383.4664 FAX	Extron Japan +81.3.3511.7655 +81.3.3511.7656 FAX	Extron China +86.21.3760.1568 +86.21.3760.1566 FAX	Extron Middle East +971.4.299.1800 +971.4.299.1880 FAX	Extron Korea +82.2.3444.1571 +82.2.3444.1575 FAX	Extron India 1800.3070.3777 (Inside India Only) +91.80.3055.3777 +91.80.3055.3737 FAX
--	--	--	---	--	---	---	---	---	---